

REVISIONS

P	LTR	DESCRIPTION	DATE	DWN	APVD
	A	INITIAL RELEASE	16DEC2014	DW	CW
	B	ECR-15-013750	19SEP2015	DW	CW
	B1	ECR-15-016224	05NOV2015	DW	CW
	B2	ECR-16-017507	12DEC2016	QY	CW

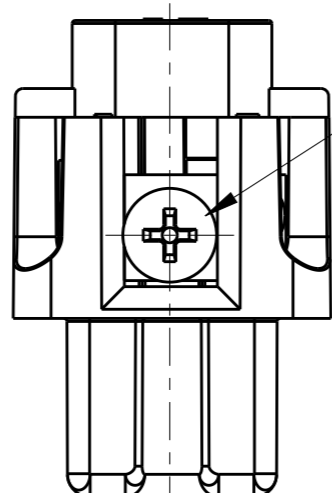
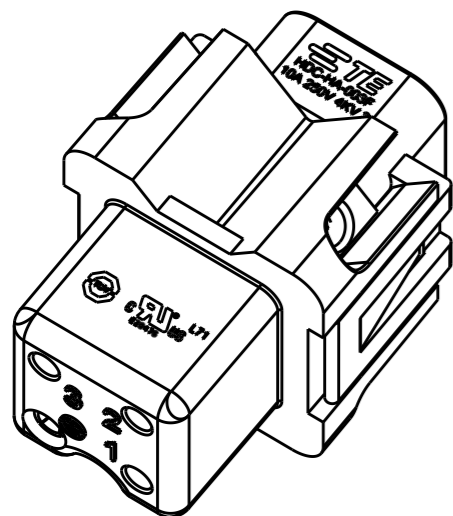

M3 SCREW, RECOMMENDED
TIGHTENING TORQUE 0.5Nm
M3 螺丝, 推荐锁紧力矩0.5Nm

TYPE-1, T2010032201-000, TE LOGO
类型-1, T2010032201-000, TE LOGO

NOTES:

- 1. TECHNICAL CHARACTERISTICS:
INSULATION MATERIAL: PC
RATED VOLTAGE: 250 V
RATED CURRENT: 10 A
INSULATION RESISTANCE: $\geq 400M\Omega$
RATED IMPULSE VOLTAGE: 4 KV
POLLUTION DEGREE: 3
FLAMMABILITY: UL94V-0
MATING CYCLES: 500 CYCLES
WIRE RANGE: 0.5-2.5 mm² (20-14 AWG)
CONTACT FINISH: SILVER PLATED
CONTACT TYPE: SCREW CONTACT

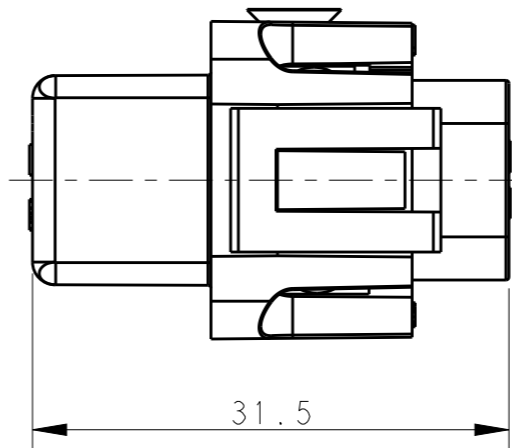
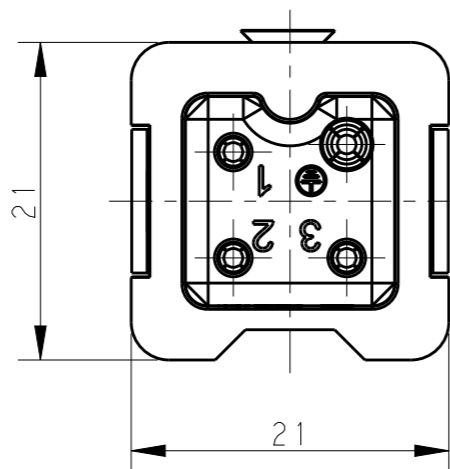

注释:

- 1. 技术参数:
绝缘材料: PC
额定电压: 250V
额定电流: 10A
绝缘电阻: $\geq 400M\Omega$
额定脉冲电压: 4 KV
污染等级: 3
阻燃等级: UL94V-0
插拔次数: 500 次
接线范围: 0.5-2.5 mm² (20-14 AWG)
端子表面处理: 镀银
接线类型: 螺丝连接

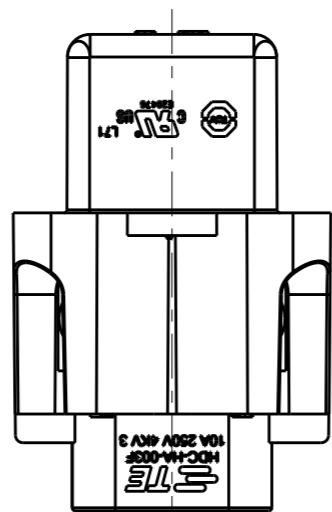

THIS DRAWING IS A CONTROLLED DOCUMENT.

DIMENSIONS:
mm

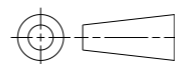

TOLERANCES UNLESS OTHERWISE SPECIFIED:

0 PLC	±-
1 PLC	±-
2 PLC	±-
3 PLC	±-
4 PLC	±-
ANGLES	±-

MATERIAL
-

FINISH
-

DWN 16DEC2014
DAVID WANG
CHK 16DEC2014
CHRIS WANG
APVD 16DEC2014
XU XIANG

PRODUCT SPEC
108-137045
APPLICATION SPEC
114-137045
WEIGHT
-



NAME
HA-003-F

SIZE	CAGE CODE	DRAWING NO	RESTRICTED TO
A3	00779	©-T2010032201000	-

Customer Drawing SCALE 2:1 SHEET 1 OF 2 REV B2

THIS DRAWING IS UNPUBLISHED.

RELEASED FOR PUBLICATION

20

© COPYRIGHT 20 BY -

ALL RIGHTS RESERVED.

REVISIONS

P	LTR	DESCRIPTION	DATE	DWN	APVD
-	-	SEE SHEET 1	-	-	-

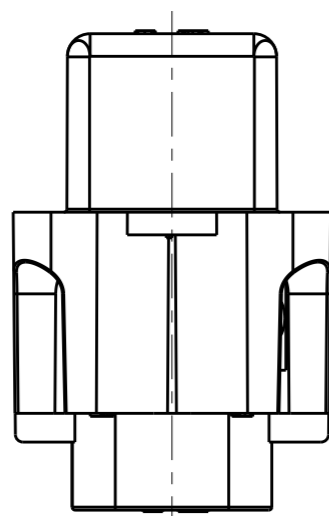
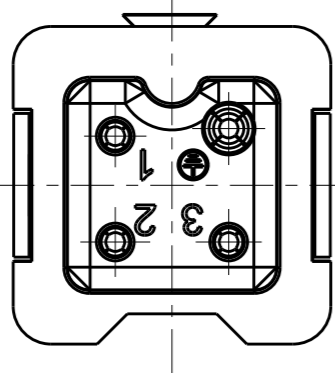
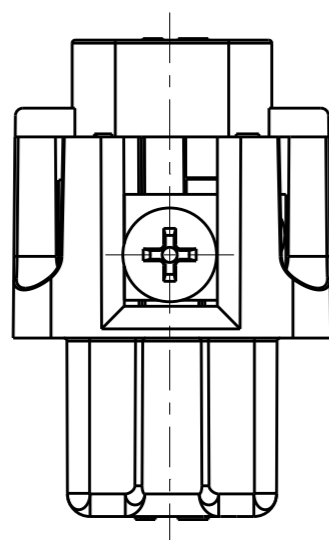

ALL DIMENSIONS ARE SAME AS TYPE 1,
EXCEPT THOSE DEFINED IN THIS TYPE.
除了在本类型中定义的尺寸外, 其它尺寸同类型 1

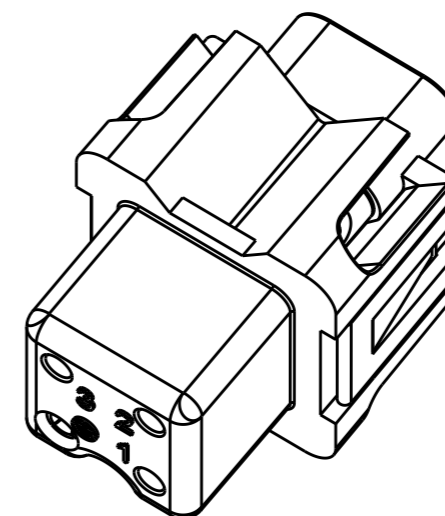
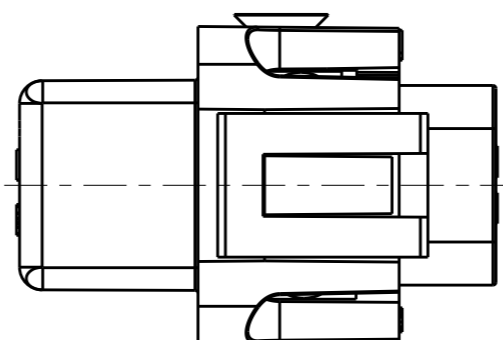

TYPE-2, T2010032201-001, NO LOGO
类型-2, T2010032201-001, 无 LOGO

NOTE:
SEE SHEET 1
注释:
见页 1

T2010032201-001	HA-003-F	HA-003 FEMALE INSERT, NO LOGO HA-003母插, 无LOGO	TYPE-2 类型-2
T2010032201-000	HA-003-F	HA-003 FEMALE INSERT HA-003母插	TYPE-1 类型-1
PART NUMBER 料号	PART DESCRIPTION 描述		TYPE 类型

THIS DRAWING IS A CONTROLLED DOCUMENT.		DWN DAVID WANG 16DEC2014		
DIMENSIONS: mm		CHK CHRIS WANG 16DEC2014		
TOLERANCES UNLESS OTHERWISE SPECIFIED:		APVD XU XIANG 16DEC2014	NAME HA-003-F	
0 PLC ±-		PRODUCT SPEC 108-137045	SIZE	
1 PLC ±-		APPLICATION SPEC 114-137045	CAGE CODE	
2 PLC ±-		WEIGHT	DRAWING NO	
3 PLC ±-		Customer Drawing	RESTRICTED TO	
4 PLC ±-		SCALE 2:1	SHEET 2 OF 2	
ANGLES ±-		REV B2		
FINISH				
MATERIAL				